



# FOX

**THERMAL INSTRUMENTS, INC.**

## Model FT4X Gas Mass Flow Meter For Oil & Gas, Industrial, and Wastewater Applications

- 2nd Generation DDC-Sensor™: Robust, non-cantilevered design
- Programmable Contract Time
- Gas-SelectX®: menu of field selectable gas compositions
- Gross Heating Value and Density Calculations of Gas Mix
- Standard Data Logger with date/time stamp and 40 24-Hour daily totals
- CAL-V® Calibration Validation
- Insertion, Inline, and Remote Styles
- Tab-style Flow Conditioners for use with insertion meters
- Measures gas flow rate in SCFM, MCFD, KG/H, & many more
- Wide measurement range: up to 1000:1 turndown; 100:1 typical
- Two 4-20mA for flow rate or temperature
- Choice of HART or RS485 Modbus RTU communication options
- USB port to connect to a PC, standard
- Free FT4X View™ Software available
- Welded, 316 SS sensor construction, Carbon Steel flow body optional
- Microprocessor based, field-programmable electronics
- Standard on-board 2 line x 16 character, backlit display with configuration panel
- NIST traceable calibration
- Low-end sensitivity for flares, vents, and leak detection
- Negligible pressure drop
- FM (U.S.) & FMc (CANADIAN) approved for Class I, Div 1; ATEX/IECEx approved for Zone 1
- NEMA 4X and CE Mark
- Accuracy Compliant with BLM 3175 & API 14.10

**FOX THERMAL INSTRUMENTS, INC.**  
 399 RESERVATION ROAD  
 MARINA, CA 93933  
 PHONE: 831-384-4300  
 FAX: 831-337-5786  
 sales@foxthermalinstruments.com  
 www.foxthermalinstruments.com

# Model FT4X

## Thermal Mass Flow Meter & Temperature Transmitter



Accuracy Compliant with  
 BLM 3175 & API 14.10

- Flare Gas • Sales Gas • Fuel Gas •

### New Standard Data Logger with Date/Time Stamp

Every FOX Model FT4X comes equipped with an advanced intrinsic Data Logger for advanced record-keeping and data retention. Data logging is commonly used in applications such as flare and waste gas monitoring, gas studies, gas royalties and allocation, and gas flow research.

To record flow, the Data Logger must be activated upon installation and setup. It can be activated quickly and easily through the flow meter's front panel keypad. The date and local time must be set for accurate records.

The Data Logger records flow rate totals and other events and alarms. The advanced features of the Model FT4X Data Logger include:

- 40 daily totals (24-hour totals)
- Settable Contract Time defines Contract Day
- Time/date stamped alarm & event logs; 7 year history
- Power off totalizer; power failure creates event log entry

The logs in the Model FT4X Data Logger also give information about the meter's settings and functionality:

- View the meter's gas or gas mix composition
- View the meter's configuration and other meter settings
- View Calibration Validation historical test data
- View and print logs of events and alarms

The Data Logger can be accessed with a RS485 MODBUS MS/TP communication option and the free FT4X View Software.

# MODEL FT4X

## Fast and Flexible Gas Flow Measurement

Offering you the flexibility to monitor multiple gas types at the push of a button, rotate the housing as needed for tight installations, and configure meter settings from advanced software, the FOX Model FT4X thermal mass flow meter and temperature transmitter can be used in a large variety of Oil & Gas, Industrial, and Wastewater gas flow measurement applications.

### Theory of Operation

FOX Thermal Flow Meters use a constant temperature differential (constant  $\Delta T$ ) technology to measure mass flow rate of air and gases. The thermal mass flow sensor consists of two Resistance Temperature Detectors (RTD's).

The Reference RTD measures the gas temperature. The instrument electronics heat the mass flow sensor, or heated element, to a constant temperature differential (constant  $\Delta T$ ) above the gas temperature and measures the cooling effect of the gas flow.

The electrical power required to maintain a constant temperature differential is directly proportional to the gas mass flow rate. The microprocessor linearizes this signal to deliver a linear 4-20mA signal.

### FOX Model FT4X Thermal Gas Mass Flow Meter Features

The FOX Model FT4X measures gas flow rate in standard units without the need for temperature or pressure compensation. It provides two isolated 4-20mA outputs, a pulse/alarm output, a contact input, and optional RS485 Modbus RTU or HART communication options.

With a standard on-board 2-line x 16-character, backlit display, operators can view flow rate, total, elapsed time, process gas temperature, and alarms. The display is also used in conjunction with the Configuration Panel to access flow meter settings, such as 4-20mA and pulse output scaling, pipe diameter, low flow cutoff, flow filtering (damping), display options, and high or low alarm limits.

The Model FT4X is available in both insertion and inline styles. The insertion probe is easily installed by drilling a hole in the pipe and welding on a 1" NPT coupling. A FOX-supplied compression fitting secures the probe in place. It is supplied with 316 stainless steel wetted materials standard. Inline models are available in 1½" to 6" sizes and includes built-in flow conditioners that eliminate the need for long, straight pipe runs.

A USB port to connect to a computer or laptop is standard; interface options include 4-20mA, pulse, HART, and RS485 Modbus RTU.

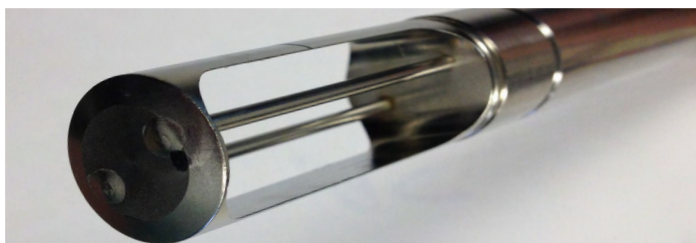

*The FOX 2nd generation DDC Sensor™ eliminates the sensor element vibration which can lead to metal fatigue and failure.*

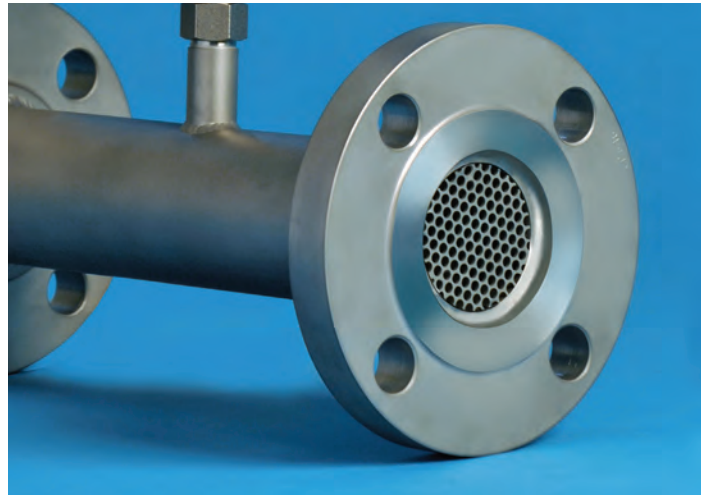

*The Model FT4X is available with inline flowbodies with built-in flow conditioners. The FT4X is approved for FM/FMc Class I, Division 1, ATEX/IECEx Zone 1. CE Mark. Accuracy compliant with BLM 3175 & API 14.10.*

### Advanced Features

Suitable for harsh and hazardous environments, the instrument features:

- Robust DDC-Sensor™ Design
- Gas-SelectX® gas selection menu featuring new Oil & Gas Menu
- Data Logger with 40 Daily Totals (24 hour totals)
- Settable Contract Time defines Contract Day
- Gross Heating Value and Density calculations of gas mix
- CAL-V® Calibration Validation
- Rotatable probe: allows  $\pm 180$  degree swivel
- FM/FMc, ATEX, IECEx approvals. CE mark.
- 10-30VDC power input, standard
- NIST-traceable calibration
- Free FT4X View™ Software

Perfect for Oil & Gas, Industrial, and Wastewater applications, the Model FT4X is the latest instrument offered in the FOX product line.

### CAL-V®

For customers that need a quick and easy way to verify the calibration of the meter in the field, the Model FT4X offers the CAL-V® feature. This feature can be accessed and run through the meter's standard display and configuration panel, Modbus, or the FT4X View™ Software. The test takes less than 5 minutes to run and produces a pass/fail result at the conclusion of the test. A fail result may indicate either a dirty sensor or the need to recalibrate.

If the CAL-V® test is performed using the FT4X View™ software, a Calibration Validation Certificate can be produced at the conclusion of the test. The certificate will show the date and time of the test along with meter data such as firmware version, meter serial number, configuration settings, and currently selected gas/gas mix. This in-situ calibration validation test helps operators comply with environmental mandates and eliminates the cost and inconvenience of annual factory calibration. View historical CAL-V® test data in the log.

## DDC-Sensor™

The FOX DDC-Sensor™ is the state-of-the-art sensor technology used in the FOX Model FT4X Thermal Gas Flow Meter. The DDC-Sensor™, a Direct Digitally Controlled sensor, is unlike other thermal flow sensors available on the market. Instead of using traditional analog circuitry, the DDC-Sensor™ is interfaced directly to the FT4X microprocessor for more speed and programmability. The DDC-Sensor™ accurately responds to changes in process variables (gas flow rate, pressure, and temperature) to determine mass flow rate, totalized flow, and temperature.

FOX's DDC-Sensor™ provides a technology platform for calculating accurate gas correlations. The FT4X correlation algorithms allow the meter to be calibrated on a single gas in the factory while providing the user the ability to select other gases or gas mixes in the Gas-SelectX® menu. FOX's Model FT4X with its DDC-Sensor™ and advanced correlation algorithm provides an accurate, multi-gas-capable thermal gas flow meter.

## Gas-SelectX® Gas Selection Menu

Many customers need a fast solution to their monitoring needs. For these cases, FOX has developed the Gas-SelectX® gas selection menu feature for the Model FT4X flow meter. Gas-SelectX® allows the user to choose from a menu of several common gases or gas mixtures for their application.

The Gas-SelectX® feature has three gas menus with the following available gases:

Pure Gas Menu	Mixed Gas Menu	O&G Gas Menu
Air	Air	Methane (C1)
Argon	Argon	Ethane (C2)
Butane	Butane	Propane (C3)
Carbon Dioxide	Carbon Dioxide	i-Butane (C4)
Methane	Methane	n-Butane (C4)
Natural Gas*	Nitrogen	Pentanes (C5)
Nitrogen	Oxygen	Hexanes (C6)
Oxygen	Helium	Carbon Dioxide
Helium	Hydrogen	Nitrogen
Hydrogen	Propane	Heptanes (C7)
Propane	Ethane	Octanes (C8)
		Nonanes + (C9+)

\*Choosing Natural Gas sets the NAESB average in a pre-programmed mix of methane, ethane, propane, nitrogen, and carbon dioxide.

The meter's proprietary algorithms allow the user to switch gases or gas mixes in the field, as needed. The Pure and Mixed Gas Menus make the FT4X ideal for measurement of digester gas, Liquefied Petroleum Gas (LPG) and a variety of other biogases.

With the O&G Menu on the Model FT4X, Gas-SelectX® contains gases common to Oil & Gas applications. Whether you need to measure natural gas, air, flare gas, vent gas, or digester gas, the FT4X brings these options and more to the user with a quick push of a button.



The Model FT4X is available with FC10 Flow Conditioners for use with insertion flow meters.

## FC10 Tab-style Flow Conditioners

FOX now offers tab-style flow conditioners for use with insertion meters. Customers want the shorter straight pipe run requirements that you can get from an inline style meter, but often require an insertion style flow meter for the lower cost and the easy installation in tight areas.

The FC10 flow conditioners are installed between two flanges upstream of the insertion flow meter and used to correct irregular flow profiles due to elbows or obstructions upstream from the meter's probe. Use of a flow conditioner helps ensure the highest flow meter accuracy.

## FT4X View™ Software

FOX has developed advanced software - FT4X View™ - a free PC-compatible application available for download from the FOX website. Connect your laptop, PC, or control station to the meter using the USB port interface to access the meter's data and configure the meter's settings.

FT4X View allows:

- Quick access to all configuration parameters and available gas selections
- Selection of measurement units, flow and temperature ranges, alarm settings and more
- Print a CAL-V Calibration Validation certificate
- Display of alarm codes
- Storage of meter configurations to a file that can be archived
- Raw data to be viewed in order to diagnose or troubleshoot your meter
- Data logging to an Excel™ spreadsheet
- View Gross Heating Value and Density of gas mix

# DIMENSIONS

## Meter Dimensional Drawings

Drawings of the Model FT4X meter and retractor dimensions are shown here in inches (mm).

**Local Styles**

### Local Insertion Meter

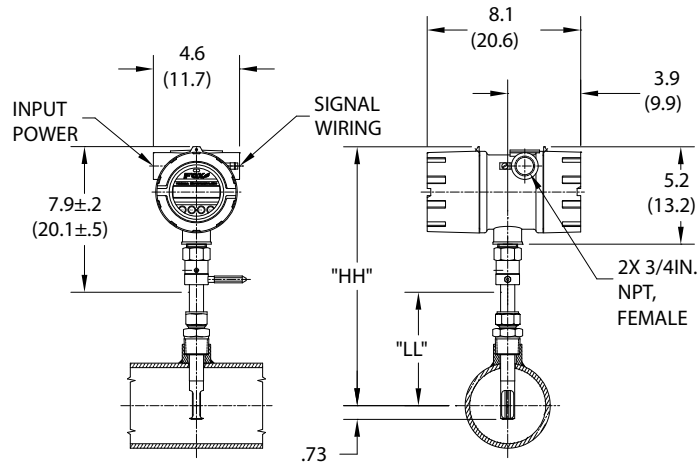

Dimensions		
Probe Length	"LL" Dim, In(cm)	"HH" Dim, In(cm)
6"	6.0 (15.2)	13.9 (35.3)
9"	9.0 (22.9)	16.9 (42.9)
12"	12.0 (30.5)	19.9 (50.5)
15"	15.0 (38.1)	22.9 (58.2)
18"	18.0 (45.7)	25.9 (65.8)
24"	24.0 (61.0)	31.9 (81.0)
30"	30.0 (76.2)	37.9 (96.3)
36"	36.0 (91.4)	43.9 (111.5)

### Local Insertion Meter with Retractor

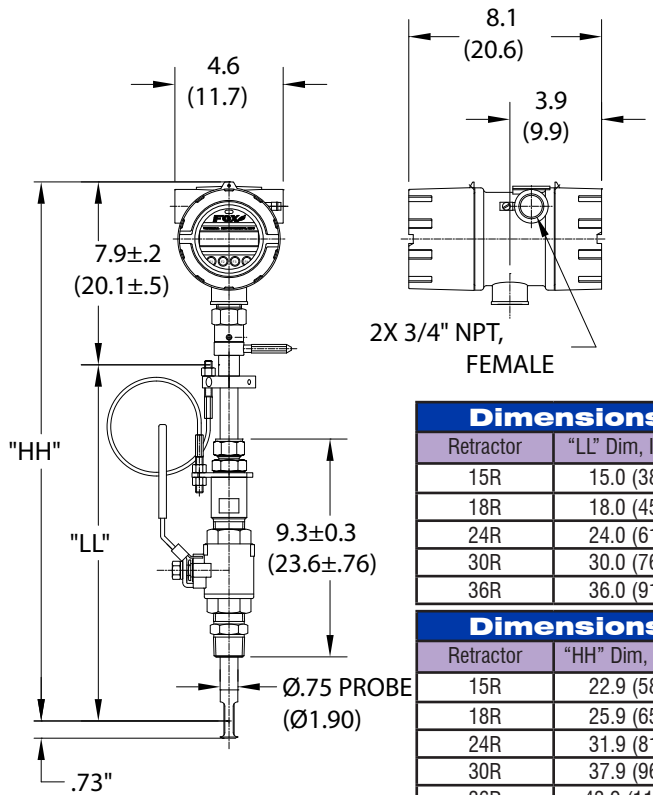

Dimensions	
Retractor	"LL" Dim, In(cm)
15R	15.0 (38.1)
18R	18.0 (45.7)
24R	24.0 (61.0)
30R	30.0 (76.2)
36R	36.0 (91.4)

Dimensions	
Retractor	"HH" Dim, In(cm)
15R	22.9 (58.2)
18R	25.9 (65.8)
24R	31.9 (81.0)
30R	37.9 (96.3)
36R	43.9 (111.5)

### Local Inline Meter with NPT Ends

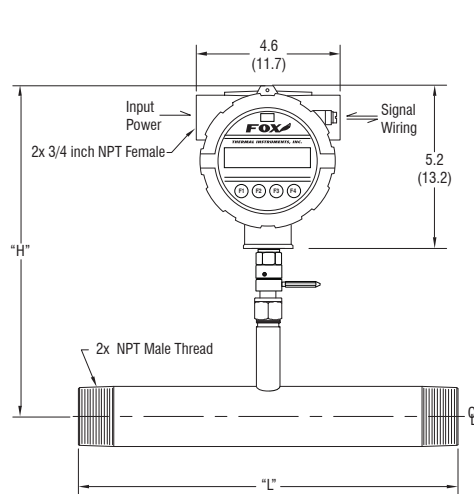

Dimensions		
Pipe Size	"L" Dim, In(cm)	"H" Dim, In(cm)
1.50"	12.0 (30.5)	10.50 (26.7)
2.00"	12.0 (30.5)	10.50 (26.7)
2.50"	18.0 (45.7)	10.60 (26.9)
3.00"	18.0 (45.7)	10.60 (26.9)

### Local Inline Meter with Flanges

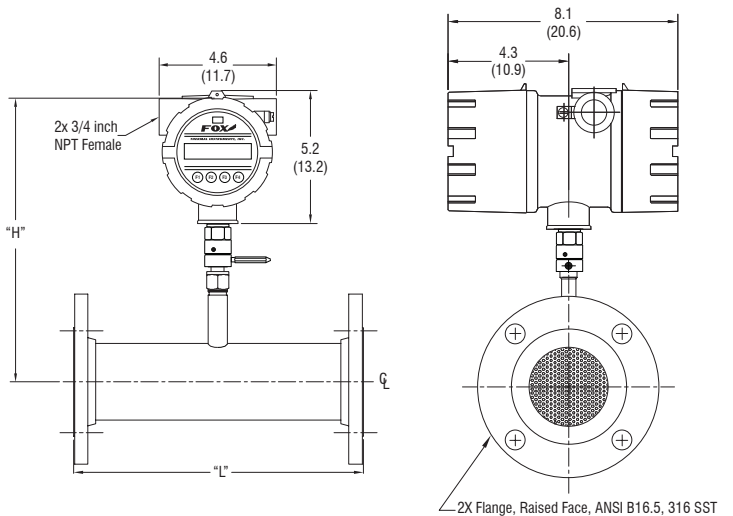

Dimensions		
Pipe Size	"L" Dim, In(cm)	"H" Dim, In(cm)
1.50"	12.0 (30.5)	10.50 (26.7)
2.00"	12.0 (30.5)	10.50 (26.7)
2.50"	18.0 (45.7)	10.60 (26.9)
3.00"	18.0 (45.7)	10.60 (26.9)
4.00"	18.0 (45.7)	11.10 (28.2)
6.00"	24.0 (60.6)	12.20 (31.0)



## Remote Styles

### Remote Insertion Meter

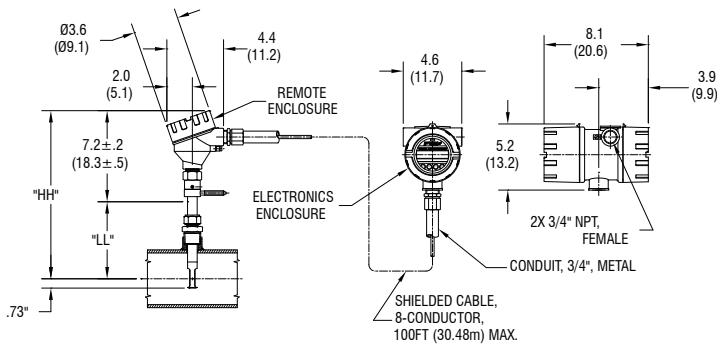

Dimensions			
Model Code	Probe Length	"LL" Dim, In(cm)	"HH" Dim, In(cm)
06I	6"	6.0 (15.2)	13.2 (33.5)
09I	9"	9.0 (22.9)	16.2 (41.1)
12I	12"	12.0 (30.5)	19.2 (48.8)
15I	15"	15.0 (38.1)	22.2 (56.4)
18I	18"	18.0 (45.7)	25.2 (64.0)
24I	24"	24.0 (61.0)	31.2 (79.2)
30I	30"	30.0 (76.2)	37.2 (94.5)
36I	36"	36.0 (91.4)	43.2 (109.7)

### Remote Insertion Meter with Retractor

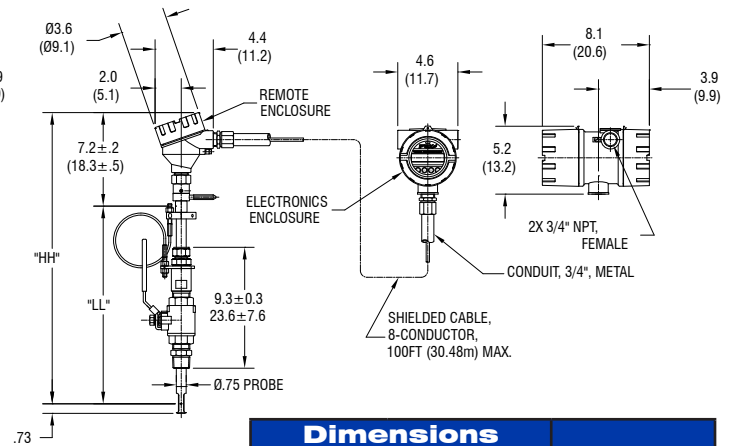

Dimensions		
Retractor	"LL" Dim, In(cm)	"HH" Dim, In(cm)
15R	15.0 (38.1)	22.2 (56.4)
18R	18.0 (45.7)	25.2 (64.0)
24R	24.0 (61.0)	31.2 (79.2)
30R	30.0 (76.2)	37.2 (94.5)
36R	36.0 (91.4)	43.2 (109.7)

### Remote Inline Meter with NPT Ends

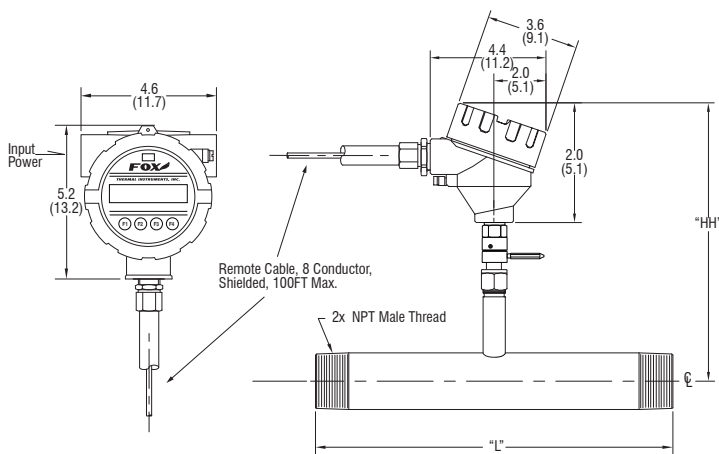

Dimensions		
Pipe Size	"L" Dim, In(cm)	"H" Dim, In(cm)
1.50"	12.0 (30.5)	10.50 (26.7)
2.00"	12.0 (30.5)	10.50 (26.7)
2.50"	18.0 (45.7)	10.60 (26.9)
3.00"	18.0 (45.7)	10.60 (26.9)

### Remote Inline Meter with 150# Flanges

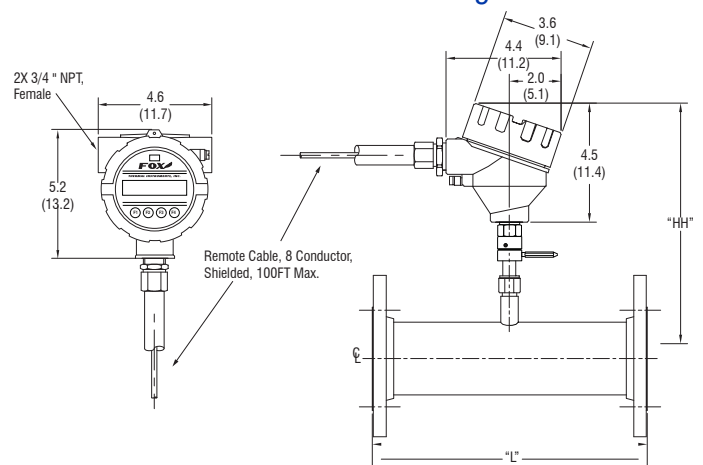

Dimensions		
Pipe Size	"L" Dim, In(cm)	"H" Dim, In(cm)
1.50"	12.0 (30.5)	10.50 (26.7)
2.00"	12.0 (30.5)	10.50 (26.7)
2.50"	18.0 (45.7)	10.60 (26.9)
3.00"	18.0 (45.7)	10.60 (26.9)
4.00"	18.0 (45.7)	11.10 (28.2)
6.00"	24.0 (60.6)	12.20 (31.0)

### Remote Mounting Kit

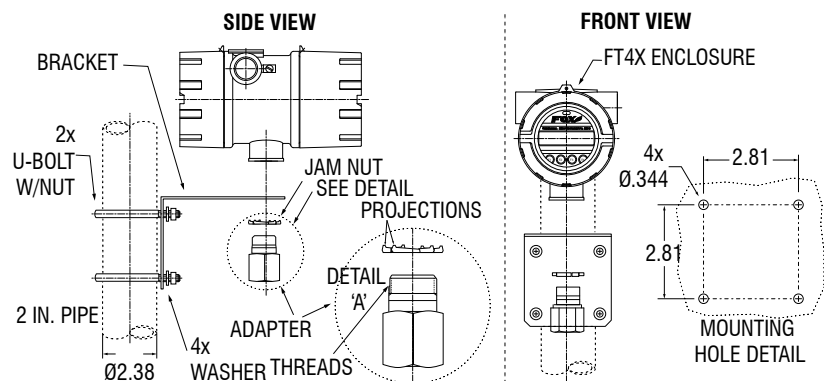

**Inline flow meter features also available:**

- 300# flanges
- Carbon steel flow bodies

# COMPARISONS

## Why Choose FOX Thermal Mass Flow Meters Over Other Technologies?

For customers searching for a lower cost, higher accuracy low flow measurement meter, thermal mass flow meters by FOX beat DP meters and the other flow technologies on the market today. Compare the new Model FT4X Thermal Mass Flow Meter and Temperature Transmitter equipped with the state-of-art DDC-Sensor

technology, new expanded Gas-SelectX® gas selection menu, and a standard Data Logger with date and time stamp as the alternative to other technologies.

Then take a look at the other benefits FOX gas mass flow meters offer over other flow measurement technologies...

	Other Technologies	Model FT4X Thermal Mass Flow
<b>Flow Measurement of gases</b>	Other technologies require multiple instruments to determine the volumetric flow rate at reference conditions.	Direct mass flow measurement of air and gases in standard volumetric units (ie MSCFD, SCFM, or NM3/H) or mass units (ie LBS/M or KG/H). Each meter has the option for the user to select a variety of flow units (see Operating Specs on p. 8).
<b>Pressure or temperature compensation</b>	Differential pressure flow meters require pressure and temperature compensation.	No additional pressure or temperature compensation is required. This is a time and cost saving measure. No additional calculations or equipment are needed to calculate flow because the meter measures the mass flow rate.
<b>Turndown</b>	Vortex meters are only suitable for very high flow rates. DP meters do not have good turndown.	Repeatability and exceptionally broad measurement range: up to 1000:1 (100:1 typical). Whether the flow is at a very high or low velocity, FOX thermal mass flow meters can measure it.
<b>Pressure Drop</b>	If a DP meter is used to measure low velocity flow, a very small orifice is required resulting in high pressure drop.	Low pressure drop. The pressure drop of a thermal mass flow meter is negligible.
<b>Moving Parts</b>	A meter with moving parts, like a Turbine meter, will need regular maintenance.	No moving parts.
<b>Price</b>	Ultrasonic meters are especially expensive.	Cost effective. Thermal mass flow meters offer a low cost alternative.
<b>Installation</b>	Some meter technologies are complicated and difficult to install, require additional equipment, or long straight pipe run requirements.	Easy to install with insertion and inline configurations. Insertion meters are easy to install, inline meters come equipped with flow conditioners to help reduce the straight run requirements. Communication options available and intrinsic to meter electronics.
<b>Operation</b>	Most manufacturers build meters for a single purpose, gas calibration, or application. The customer must sift through pages of specs to find the right meter for their application. This is time consuming and ineffective.	Microprocessor based, field rangeable electronics. FOX pioneered the use of microprocessors in thermal mass flow meters and continues to create innovative solutions to measurement needs across many industries and applications. Gas-SelectX®, available in the Model FT4X, allows the user to change the gas selection in the field. Displays with configuration panels and free software allow users to interact and program the meter in the field. Using the online Product Configurator, the customer can enter process data into the system for an instant FOX Product recommendation: no need to search a list of meters for the one that's right for you!

## Approvals

CE Mark: Approved  
 EMC Directive: 2014/30/EU  
 Electrical Equipment for Measurement, Control, and Lab Use:  
 EN61326-1:2013

FM (U.S.) & FMc (CANADA): Approved  
 Class I, Division 1, Groups B, C, D; Class II, Division 1, Groups E, F, G; and Class III, Division 1; T4, Ta = -40° to 70° C; Class I, Zone 1, AEx/Ex db IIB + H2 T4; Gb Ta = -40° to 70° C; Type 4X, IP67

ATEX (FM16ATEX0013X): Approved  
 II 2 G Ex db IIB + H2 T4; Gb Ta = -40° to 70° C; IP67  
 II 2 D Ex tb IIIC T135° C; Db Ta = -40° to 70° C; IP67

IECEX (IECEX FMG 16.0010X): Approved  
 Ex d IIB + H2 T4; Gb Ta = -40° to 70° C; IP67  
 Ex tb IIIC T135° C; Db Ta = -40° to 70° C; IP67

ATEX and IECEX Standards:  
 EN 60079-0:2012 + A11:2013 IEC 60079-0:2011  
 EN 60079-1:2014 IEC 60079-1:2007  
 EN 60079-31:2014 IEC 60079-31:2008  
 EN 60529:1991 + A1:2000 IEC 60529:2001

## CONFIGURATIONS

### Choose Your Meter's Features

The Model FT4X is available in insertion, inline, and remote styles. The insertion meter is easily installed with a weld-o-let and compression fitting and requires straight pipe runs of 15D upstream/10D downstream. The inline model is available in 1½" to 6" sizes and includes built-in flow conditioners that eliminate

the need for long, straight pipe runs. Straight run requirements are decreased to 8D upstream/4D downstream for the inline style meters. FC10 Flow Conditioners are available for insertion style meters and further reduce the straight run requirements. In a remote configuration, the electronics can be mounted up to 100' from the sensor.

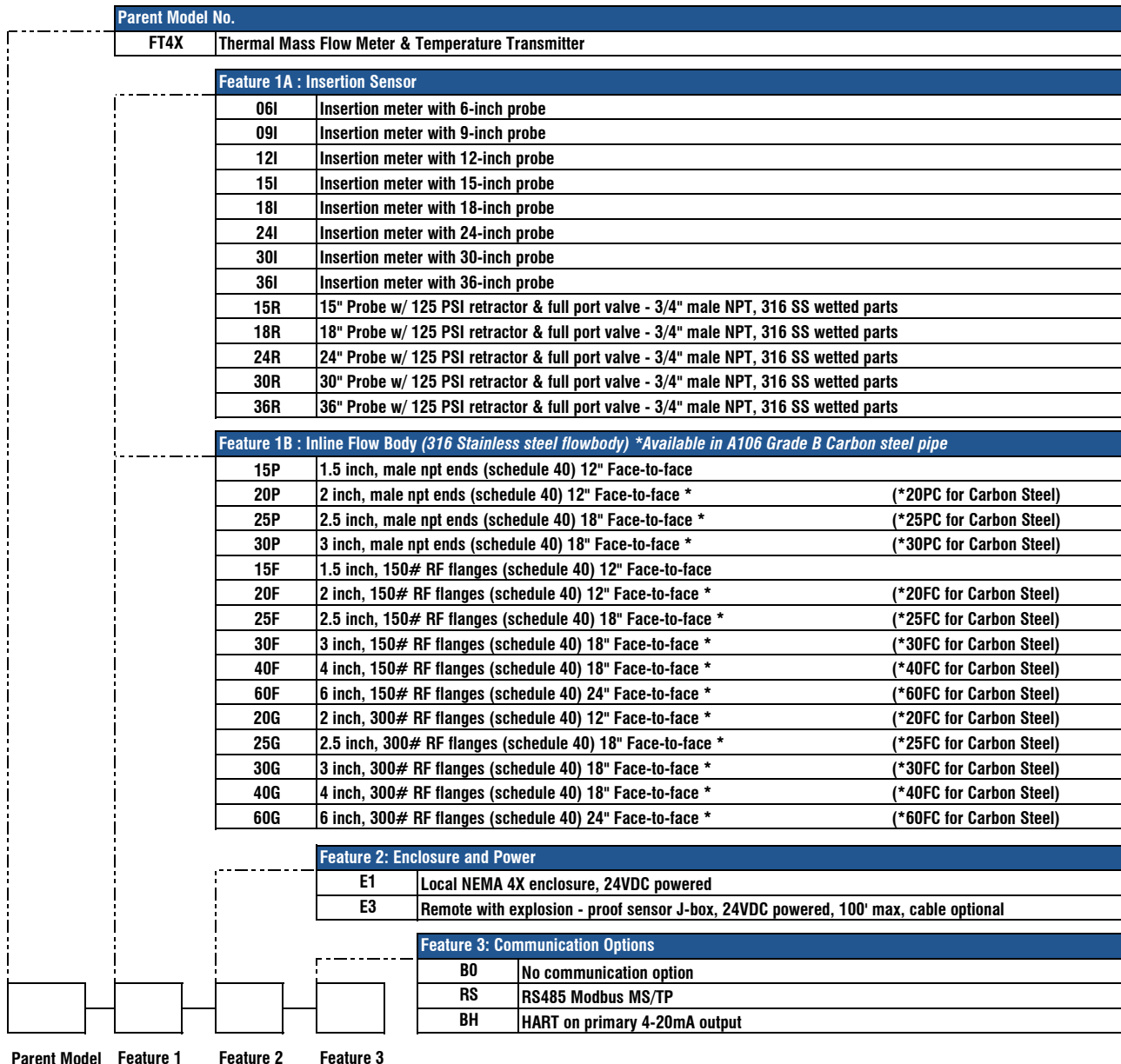

# SPECIFICATIONS

## Performance Specs

### Flow Accuracy:

- Air:  $\pm 1\%$  of reading  $\pm 0.2\%$  of full scale
- Other gases:  $\pm 1.5\%$  of reading  $\pm 0.5\%$  of full scale
- Accuracy specification applies to customer's selected flow range
- Maximum range: 15 to 60,000 SFPM (0.07 to 280 NMPS)
- Minimum range: 15 to 1,000 SFPM (0.07 to 4.7 NMPS)
- Straight, unobstructed pipe requirement:
- Insertion: 15 diameters upstream 10 downstream
- Inline: 8 diameters upstream, 4 downstream

### Flow Repeatability: $\pm 0.2\%$ of full scale

### Flow Response Time: 0.8 seconds (one time constant)

### Temperature Accuracy: $\pm 1^\circ\text{F}$ ( $\pm 0.6^\circ\text{C}$ )

### Calibration:

- Factory Calibration to NIST traceable standards
- CAL-V<sup>®</sup>: In-situ, operator-initiated calibration validation

## Operating Specs

### Gas-SelectX<sup>®</sup> Gas Selections:

Pure Gas, Mixed Gas, and Oil & Gas Mixed Gas Menus to suit any application. See the FOX website for more information on availability of current gases.

### Units of Measurement:

SCFM, SCFH, NM3/M, NM3/H, NM3/D, NLPS, NLPM, NLPH, MCFD, MSCFD, SCFD, MMSCFD, MMSCFM, SM3/D, SM3/H, SM3/M, LB/S, LB/M, LB/H, LB/D, KG/S, KG/M, KG/H, SLPM, MT/H

### Gas Pressure (maximum; at 100°F):

- Insertion meter: 740 psig (51.02 barg)\*
- Inline meter: NPT 500 psig (34.5 barg); 150# flange 230 psig (16 barg); 300# flange 600 psig (41.4 barg)
- Retractor: 150 psig (10.3 barg)
- Check with factory for higher pressure options.
- \*NOTE! When teflon ferrule option ordered, gas pressure is 60psig (4.1 barg) maximum.

### Relative Humidity: 90% RH maximum; non-condensing

NOTE! Condensing liquids contacting the sensor can cause erratic flow indication.

### Temperature:

- DDC-Sensor<sup>™</sup>: -40 to 250°F (-40 to 121°C)
- Enclosure: -40 to 158°F (-40 to 70°C)\*
- Remote Sensor Enclosure: -40 to 158°F (-40 to 70°C)
- \*NOTE! Display dims below -4°F (-20°C); function returns once temperature rises again.

### Flow Velocity Range: 15 to 60,000 SFPM (0.07 to 280 NMPS)

Turndown: up to 1000:1; 100:1 typical

Flow Ranges - Insertion Meters			
Pipe Diameter	SCFM	MSCFD	NM3/Hr
1.5" (40mm)	0 - 840	0 - 1,220	0 - 1,325
2" (50mm)	0 - 1,400	0 - 2,020	0 - 2,210
3" (80mm)	0 - 3,100	0 - 4,440	0 - 4,890
4" (100mm)	0 - 5,300	0 - 7,650	0 - 8,360
6" (150mm)	0 - 12,000	0 - 17,340	0 - 18,930
8" (200mm)	0 - 20,840	0 - 30,020	0 - 32,870
10" (250mm)	0 - 32,800	0 - 47,250	0 - 51,740
12" (300mm)	0 - 46,600	0 - 67,180	0 - 73,500

NOTE! To determine if the FT4X will operate accurately in other pipe sizes, divide the maximum flow rate by the pipe area. The application is acceptable if the resulting velocity is within the velocity range above. Check FOX website for velocity calculator.

## Dimensional

Probe diameter:  $\frac{3}{4}$ "

Equation for selecting flow meter probe length:

Probe length =  $\frac{1}{2}$  pipe ID (in inches) + 3" + 10" (for retractor, if any) + thickness of insulation (if any). Round up to the next standard probe length available.

Flow Ranges - Inline Meters			
Pipe Diameter	SCFM	MSCFD	NM3/Hr
1.5" (40mm)	0 - 840	0-1,220	0 - 1,320
2" (50mm)	0 - 1,400	0-2,020	0 - 2,204
2.5" (63mm)	0 - 2,000	0-2,880	0 - 3,150
3" (80mm)	0 - 3,100	0-4,440	0 - 4,890
4" (100mm)	0 - 5,300	0-7,650	0 - 8,360
6" (150mm)	0 - 12,000	0-17,340	0 - 18,930

NOTE! Consult factory for flow ranges above those listed. Inline meters above 5,000 SCFM (7,900 NM3/H) air may require third party calibration. Contact Fox.

Input power: 12 to 28 VDC, 6 watts max.

Full input power range: 10 to 30 VDC.

A 20 Watt or greater power supply is recommended to power the FT4X

Class I Equipment (Electrical Grounding Required for Safety).

Installation (Over-voltage) Category II for transient over-voltages.

### Inputs/Outputs:

#### 4-20mA Channel 1:

- Standard isolated 4-20mA output configured to indicate for flow; fault indication per NAMUR NE43. HART communication option.
- The 4-20mA load resistance must be 125 ohms or less when operating on 12 volt power and 600 ohms or less on 24 volt power.

#### 4-20mA Channel 2:

- Standard isolated 4-20mA output configured to indicate either flow or temperature.

### Pulse/Alarm:

- Isolated open collector output rated for 5 to 24VDC, 10mA maximum load, 0 to 100Hz (the pulse output can be configured to either transmit a 0 to 100Hz signal proportional to flow rate or an on/off alarm).

### Remote Switch Input:

- Can be configured to reset the flow totalizer and elapsed time.

### Serial Communication:

- Isolated RS485 Modbus RTU option
- Isolated HART communication option

### USB Communication:

- Isolated USB 2.0 for interfacing with a laptop or computer is standard.
- FT4X View<sup>™</sup>: A free PC-based software tool that provides complete configuration, remote process monitoring, and data logging functions through USB communication.

### 4-20mA and Loop Verification:

Simulation mode used to align 4-20mA output with the input to customer's PLC/DCS.

## Physical Specs

Sensor Material: 316 stainless steel

Enclosure: NEMA 4X (IP67), aluminum, dual  $\frac{3}{4}$ " FNPT conduit entries.

Cabling to remote enclosure: 8-conductor, 18 AWG, twisted, shielded, 100 feet maximum.

Insertion flow meter installation: Fox-supplied compression fitting connects to customer-supplied 1" female coupling welded to pipe. FOX recommends the following probe lengths (without insulation):

Pipe Diameter	Probe Length
1.5" (40mm) to 6" (150mm)	6-inch
8" (200mm) to 12" (300mm)	9-inch
14" (350mm) to 18" (450mm)	12-inch

Probe Lengths (LL\*) in inches(cm) =

6.0 (15.2)	9.0 (22.9)	12.0 (30.5)
15.0 (38.1)	18.0 (45.7)	24.0 (61.0)
30.0 (76.2)	36.0 (91.4)	

\*See dimensional drawings on pages 4 and 5.